

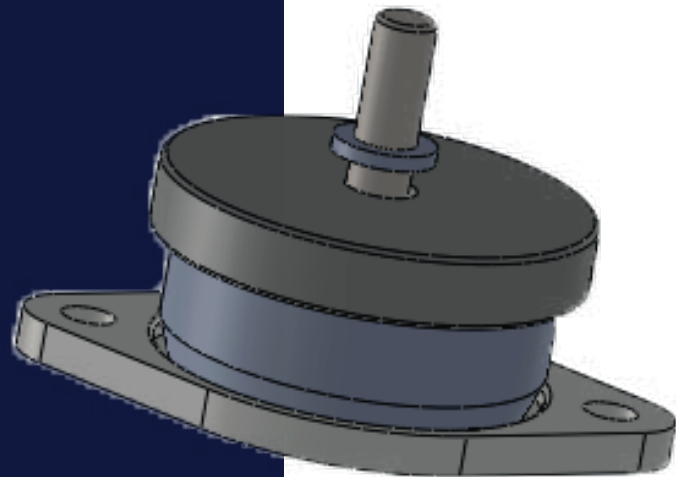

POONA  
COUPLINGS  
PVT. LTD.



---

# ANTI - VIBRATION MOUNT

---

INDUSTRIAL RANGE

## RR SERIES

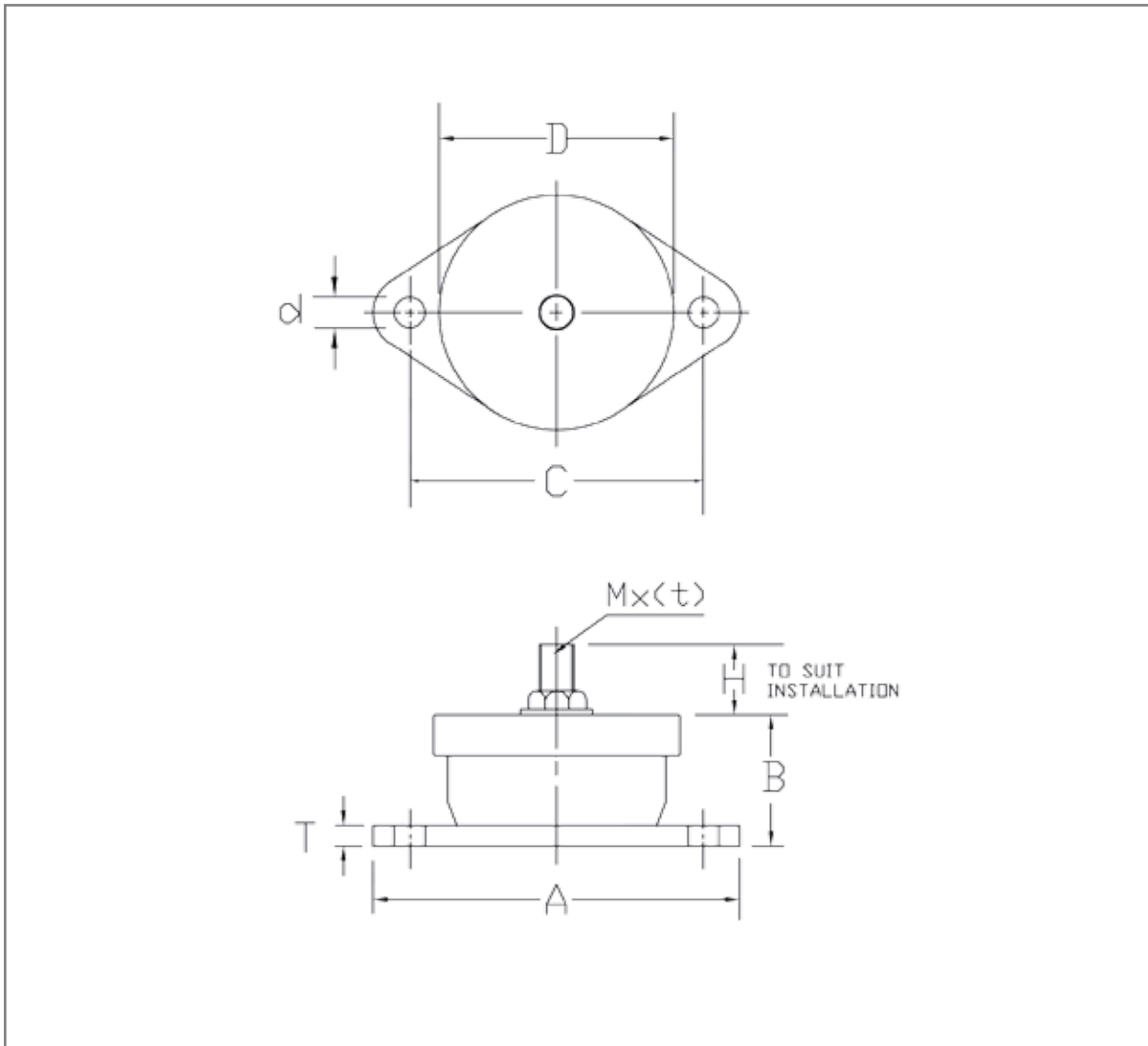

MOUNT SIZE	RANGE Kg/Mount	A	B	C	D	Mx (t)	T	d
100	50 - 120	100	32	78	57	M - 8	6	8.5
200	150 - 300	125	43	100	84	M - 12	8	10.5
400	300 - 650	190	65	160	120	M - 16	12	12.5
800	600 - 1200	240	85	200	160	M - 20	14	16.5

Ideally suited for static as well as mobile operations in

- Diesel Engines
- Generator Sets
- Pumps
- Compressors
- Centrifugers
- Industrial Equipment

## TECHNICAL DATA

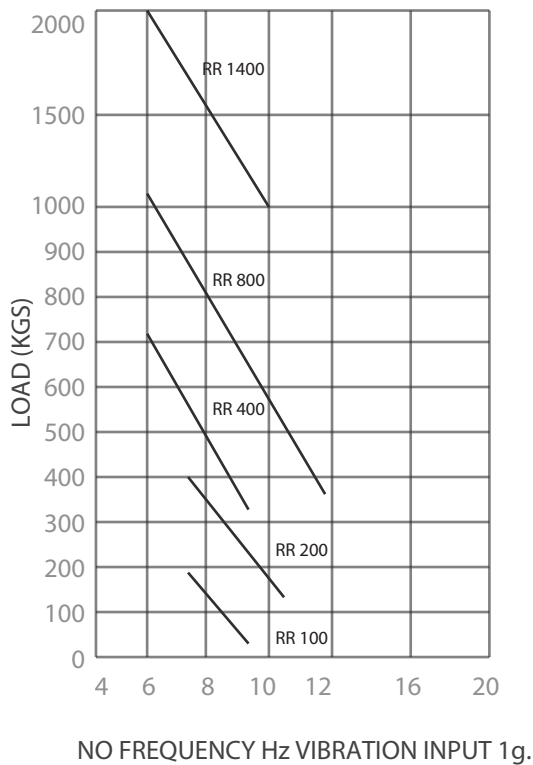
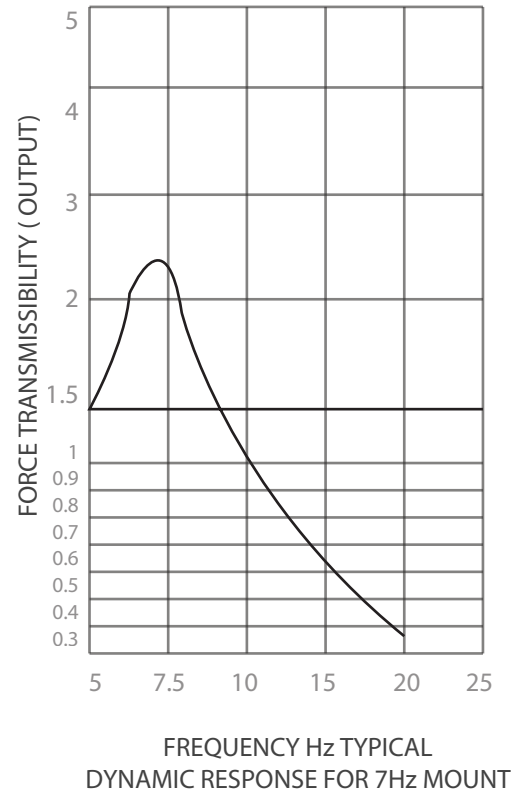
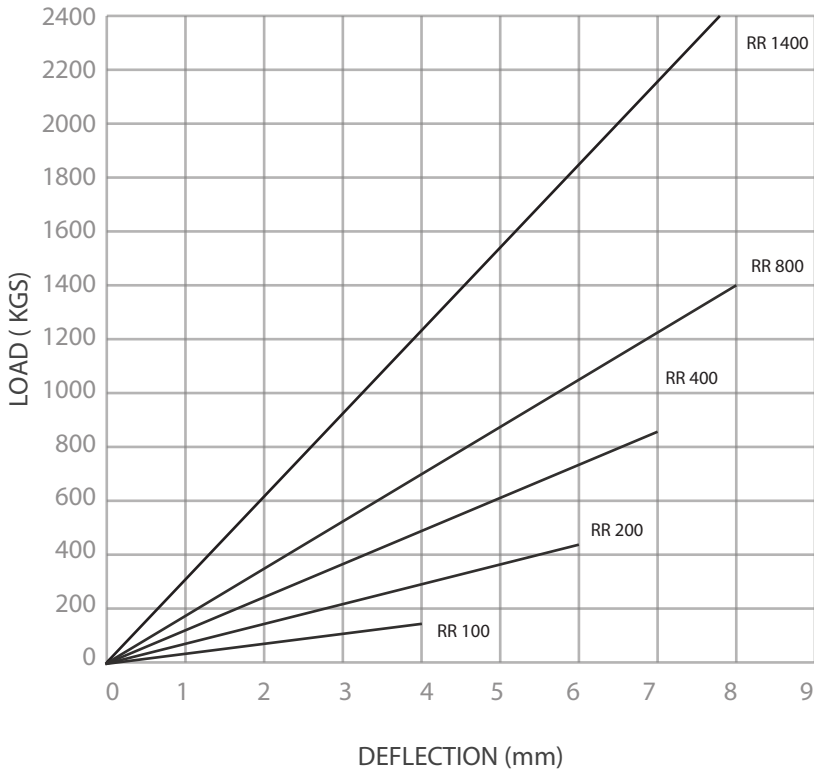

- Normal operating temperature: -20°C to 100°C can be extended from -40°C to 120°C with special rubber composition.
- Natural frequency can be as low as 6 Hz when using larger size mounts.
- Rugged construction using high grade CI base, Steel top plate & fail safe rubber in compression element design.
- Standard elastomer is oil resistant nitrile with 70 shore hardness combined with internal damping co-efficient of 0.2
- Other elastomers and different hardnesses are available for custom built mounts.

## RT SERIES - INTRODUCTION

The Emount - Series M vibration isolation mount is a unique rubber - in compression design using a two element buffer system with synthetic elastomer moulding, high strength Cast Iron base and Steel top plate. Standard arrangement includes height adjustment feature.

The elastomeric moulding is designed to have a controlled pre-compression with linear performance over the design load range, and then becoming progressively stiffer at high deflections for safer progressive shock absorption. The two element design allows for equal load performance in both the loading and rebound directions in compression.

Operating temperature range is from  $-20^{\circ}\text{C}$  to  $+140^{\circ}\text{C}$ .

The synthetic elastomer is resistant to oils, diesel fuel, water and other liquid contaminants. Standard rubber hardness of 65 shore is available. But on request, others can be ordered, (50 shore being the normal alternative).

Long bolts are used for simple, precise height adjustment. Metal parts (including) the nuts and bolts) are treated against corrosion by powder coating or plating.

The range of 5 sizes cover the vast majority of applications particularly the following:

Marine Propulsion where propeller thrust is present

Diesel Generator Sets

Diesel Pump Sets

Diesel Compressor Sets

Industrial Equipment

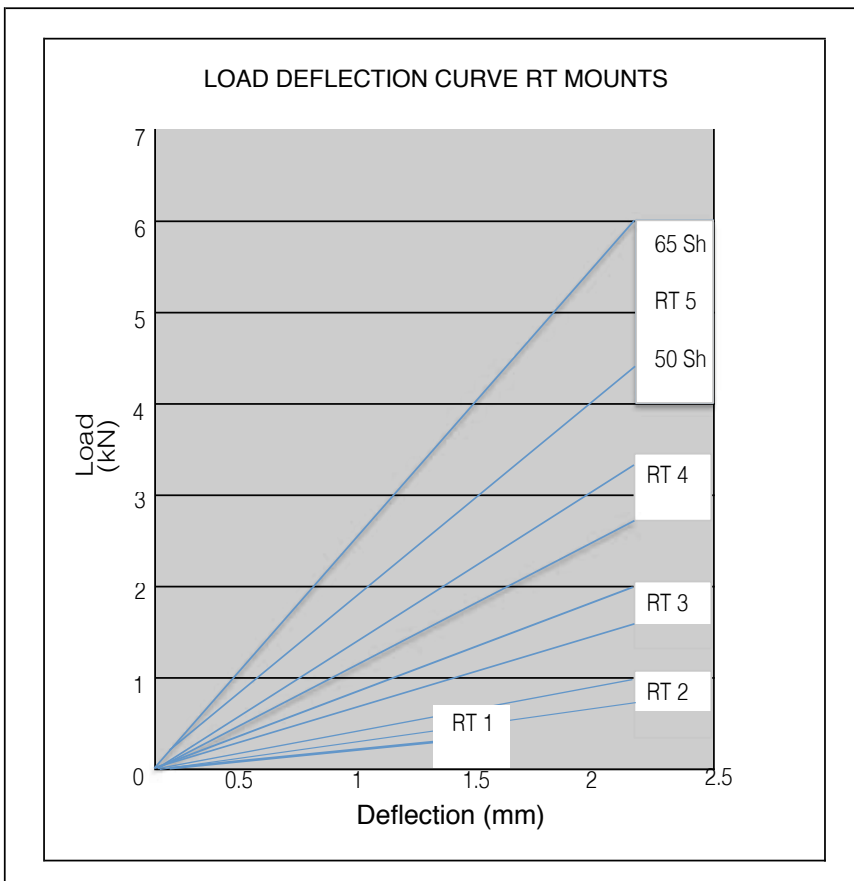

Recommended Load Range per mount. Load range is expressed in Newton (N)  $1\text{N} = 9.81 \times \text{Kg}$

RT1/

50shore 80N - 260N

65shore 120N - 400N

RT2/

50shore 200N - 800N

65shore 350N - 1kN

RT3/

50shore 600N - 1.6kN

65shore 750N - 2kN

RT4/

50shore 780N - 2.6kN

65shore 1kN - 3.4kN

RT5/

50shore 1kN - 4.4kN

65shore 1.2kN - 6kN

## DIMENSIONAL DATA

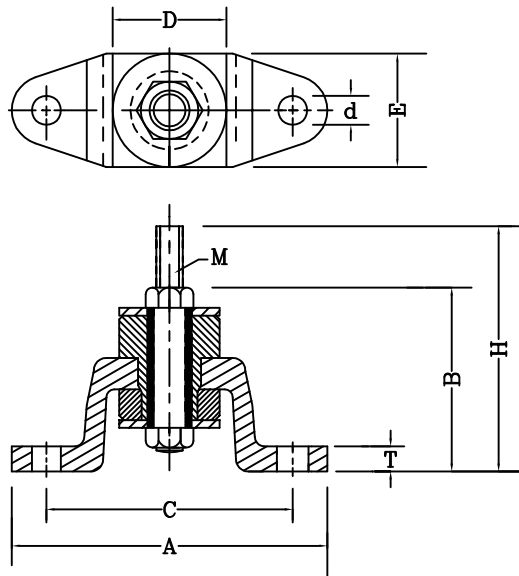

TYPE			A	B	C	D	E	T	d	w	M	H
RT			mm	mm	mm	mm	mm	mm	mm	mm	mm	mm
SIZE	SHORE	N/ mount	mm	mm	mm	mm	mm	mm	mm	mm	mm	mm
1	50	80 - 260	100	57	78	34	36	6	8.5	11	M10 x 1.25	90
	65	120 - 400										
2	50	200 - 800	125	78	100	50	52	8	11	14	M12 x 1.25	125
	65	350 - 1 kN										
3	50	600 - 1.5 kN	180	100	140	68	70	12	13	16	M16 x 2.0	160
	65	750 - 2.6 kN										
4	50	780 - 2.6 kN	210	110	182	90	92	12	13	16	M16 x 2.5	160
	65	1 kN - 3.4 kN										
5	50	1 kN - 4.4 kN	240	120	210	100	102	16	13	16	M16 x 2.5	170
	65	1.2 kN - 6 kN										

ORDER CODE	SIZE	SHORE HARDNESS	STUD THREAD	FOOT HOLE PITCH	FOOT HOLE DIA
RT	2	65	16	140	13

TABLE OF TIGHTENING TORQUES	
THREAD	TIGHTENING TORQUES
M10 X 1.25	60
M12 X 1.5	80
M16 X 2.0	190
M20 X 2.5	380

Threads should be clean and free of grease.

Tightening torque tolerance = +/-5%.

## Installation Advice

1. If possible, design the machinery mount position to place an equal load on each mount.
2. Should there be unequal loading, compensate the height difference using the adjustment features.
3. Machinery alignments should be checked annually and re-adjusted with the height adjustment feature.
4. Prevent heavy contamination of oils locally to the mount.

## PROPERTIES OF FLEXIBLE MOUNTED MACHINERY INSTALLATION

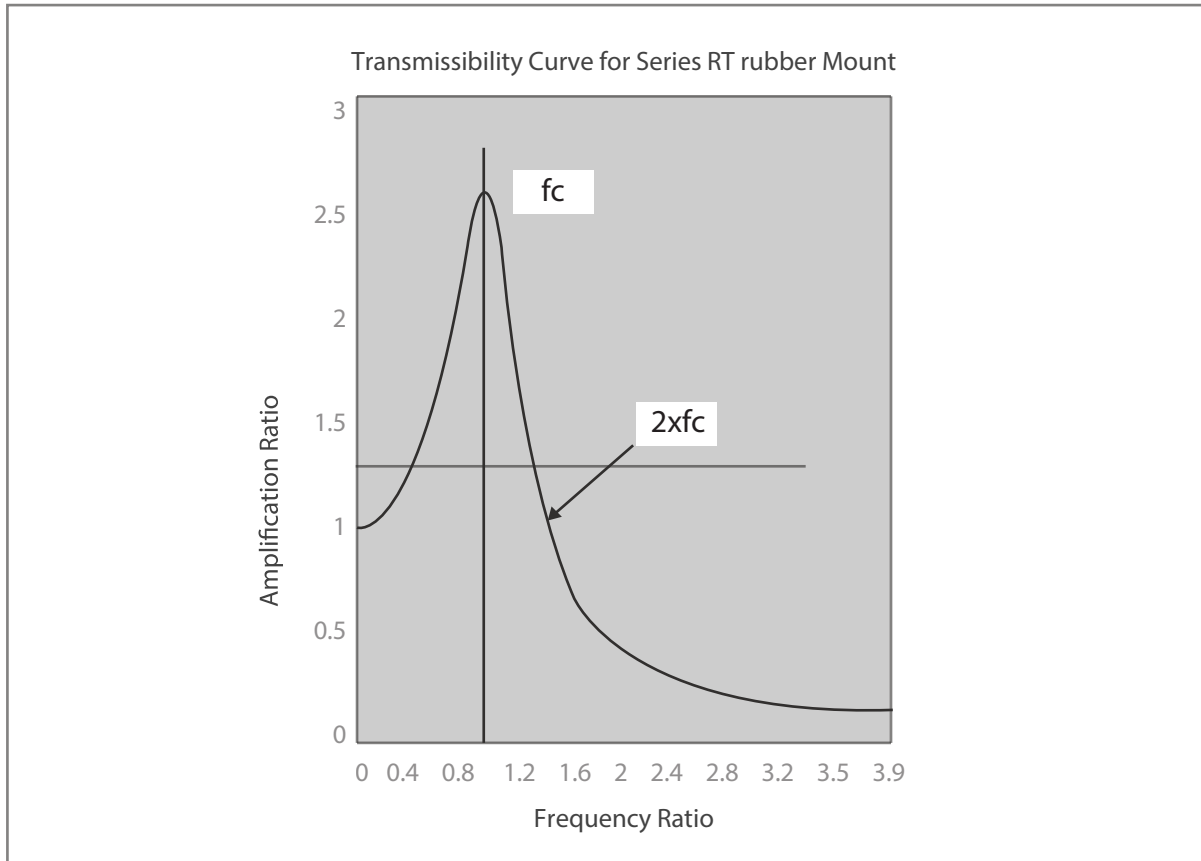

The level of vibration achieved with the Series - RT mount is a function of the total load and the stiffness of the complete mounting system, (of which the mounts are a principal component), they determine the natural frequency of the suspension system.

When the suspended machinery is subject to a regular sinusoidal force (or forces) from a diesel engine, or other reciprocating, or out - of - balance machine, vibration isolation can only be achieved if the natural frequency of the suspended system is designed lower than  $2xfc$  of the excitation frequency. By designing a suspension system natural frequency considerably lower than  $2xfc$  achieves progressively improved vibration isolation.

Care should be exercised in designing too high a flexibility, as the system can become unnecessarily unstable causing the suspended machinery to move excessively.

### Sound Isolation

Sound is an audible structure borne noise. The audible range is 16 Hz to 16 kHz and generally well above the suspension natural frequencies which then allow the mount system to provide a very effective barrier to noise transmission.

### Shock Isolation

A single non - periodic impact is considered a shock input. Up to 3x static load is permissible on Series RT mount without damage. Energy absorption is achieved by hysteresis damping of the elastomeric element.

## ENGINEERED TO ORDER COUPLINGS (ETO)

---

We design and manufacture couplings to custom fit the drive and driven components for one to one replacement. Our engineering expertise create value added offering for the products by taking efforts to design, develop, analyse, engineer and test.

Engineered to Order Couplings (ETO):

Cardan Shaft

Spacers of various dimensions

Floating / Long Shaft for large DBSE

Brake Disc / Brake Drum

Stub Shaft

Limited End Float

Underwater Coupling

Shear Pin Device

Long Boss Hubs for increased shaft engagement

Splined Hub

Special Adapters

Slim Line

Uni - Directional Couplings



PCPM 600 Spacer Coupling of 1200 mm dia used in a ball mill application for a gold mine in South Africa.



PCPM 27 Underwater Coupling with Shear Pin device on a river dredger in Greece.



Special PCRB 150 Coupling with splined hub for pump application.



PCPM 40 Cardan Shaft Coupling for fan drive where motor was coupled to VFD for power saving to replace fluid coupling. DBSE was more than 2 mtrs. This was for a steel plant.



High temperature blind assembly coupling.

# GLOBAL PRESENCE



Regd Office: 'Sumali', 49/A/4 Erandwane,  
Gulmohar Path, Pune, 411004, India



Works : Gat No. 106, At & Post Pirangut,  
Taluka Mulshi, Dist. Pune 412108,  
Maharashtra, India.



+ 91 8087090164 / 5



sales@poonacouplings.com  
marketing@poonacouplings.com  
www.poonacouplings.com