



POONA
COUPLINGS
PVT. LTD.



PCI COUPLINGS

INDUSTRIAL RANGE

PCI SHAFT TO SHAFT
RIGID HALF / FLEX HALF

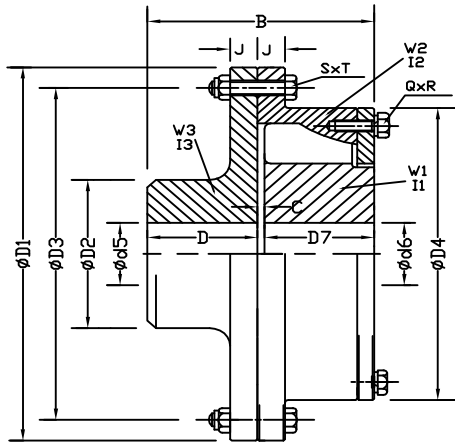

PCI SHAFT TO SHAFT
WITH INCREASED SHAFT ENGAGEMENT
RIGID HALF / FLEX HALF

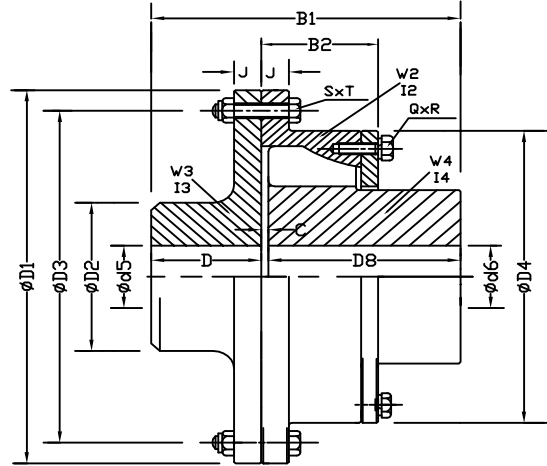

COUPLING SIZE		PCI 1.4	PCI 2.1	PCI 2.6	PCI 4	PCI 8	PCI 12	PCI 23	PCI 40	PCI 60
Inertia (2) (kgm ²)	I1	0.0044	0.0084	0.0131	0.0233	0.0563	0.1399	0.3227	0.8489	1.9633
	I2	0.0232	0.0375	0.0546	0.0887	0.2000	0.3674	1.1035	1.9161	3.4391
	I3	0.0153	0.0270	0.0396	0.0644	0.1475	0.2862	0.7998	1.5120	2.9796
	I4	0.0059	0.0121	0.0193	0.0326	0.0770	0.1896	0.4347	1.1833	2.8953

COUPLING SIZE		PCI 1.4	PCI 2.1	PCI 2.6	PCI 4	PCI 8	PCI 12	PCI 23	PCI 40	PCI 60	
Dimensions (mm)	D1	200.0	222.2	238.1	260.3	308.0	358.8	466.7	508.0	571.5	
	B	104.8	111.2	123.8	136.5	174.6	193.7	233.4	260.4	285.8	
	B1	139.0	152.2	173.5	189.9	233.9	268.4	309.1	343.4	386.1	
	B2	54.0	57.2	63.5	69.8	88.9	98.4	119.1	133.4	146.0	
	C	3.2	3.2	3.2	3.2	3.2	3.2	4.8	6.4	6.4	
	D	50.8	54.0	60.3	66.7	85.7	95.2	114.3	127.0	139.7	
	D7	50.8	54.0	60.3	66.7	85.7	95.2	114.3	127.0	139.7	
	D8	85.0	95.0	110.0	120.0	145.0	170.0	190.0	210.0	240.0	
	D2	79.4	95.2	101.6	120.6	152.4	184.1	222.2	279.4	330.2	
	D3	177.80	200.00	212.70	235.00	279.40	323.80	438.15	469.90	542.92	
	D4	156.5	178.0	186.5	210.0	251.0	295.0	362.0	435.0	501.5	
	J	12.7	14.3	15.9	17.5	19.0	19.0	19.0	22.2	25.4	
	Q	5	6	6	6	6	6	6	7	8	
	R	M8	M8	M8	M10	M10	M12	M12	M12	M12	M12
	S	6	10	6	8	8	18	16	22	22	
	T	M8	M8	M10	M10	M12	M12	M12	M12	M16	M16
	Max. d5	50	60	65	80	95	115	140	170	210	
	Max. d6	55	70	75	85	95	115	140	170	210	
Min. d5 & d6	30	35	40	40	55	55	70	80	90		
Rubber Elements	Per Cavity	1	1	1	1	1	1	1	1	1	
	Per Coupling	10	12	12	12	12	12	12	14	16	
Maximum Speed (rpm) (1)		5250	4725	4410	4035	3410	2925	2250	2070	1820	
Weight (kg) (2)	W1	2.82	4.04	5.29	7.49	12.82	23.39	35.88	62.81	102.09	
	W2	4.00	5.05	6.38	8.14	13.29	18.41	33.98	43.87	59.00	
	W3	4.06	5.82	7.42	10.44	18.03	27.37	47.43	75.39	113.32	
	W4	4.21	6.42	8.67	11.85	19.43	35.28	53.81	95.50	162.79	
Allowable Misalignment (3)											
Radial (mm)		0.75	0.75	0.75	0.75	1.00	1.50	1.50	1.50	1.50	
Axial (mm)		1.5	1.5	1.5	1.5	1.5	1.5	2.0	3.0	3.0	
Angular (degree)		0.5	0.5	0.5	0.5	0.5	0.5	0.5	0.5	0.5	

(1) For operation above 80% of the declared maximum coupling speed, it is recommended that the coupling is dynamically balanced.

(2) Weights and inertias are based on the maximum bore size.

(3) Installations should be initially aligned as accurately as possible. In order to allow for deterioration in alignment overtime, it is recommended that initial alignment should not exceed 25% of the above noted data. The forces on the driving and driven machinery should be calculated to ensure that these do not exceed the manufacturers allowables.

GENERAL PURPOSE RANGE MANUFACTURED IN SG IRON FOR TORQUES UP TO 60 kNm

Features

- Intrinsically fail safe
- Control of resonant torsional vibration
- Maintenance free
- Severe shock load protection
- Misalignment capability
- Zero backlash
- Low cost

Construction Details

- Spheroidal graphite to BS 1563 Grade 400 / 15
- Separate rubber elements with a standard SM 80 shore hardness
- Rubber elements are totally enclosed and loaded in compression

The Standard Range Comprises

- Shaft to shaft
- Shaft to shaft with increased shaft engagement

Benefits

- Ensuring continuous operation of the drive-line in the unlikely event of rubber damage
- Achieving low vibratory loads in the drive-line characteristics
- With no lubrication or adjustment required resulting in low lifetime costs
- Avoiding failure of the drive-line under short circuit and other transient conditions
- Allows axial and radial misalignment between the driving and driven machines
- Eliminates torque amplifications through pre-compression of the rubber elements

Applications for Electric Drives only

- Rubber processing and plastics industry
- Fluid transmission industry
- Material Handling
- Cranes & Hoists
- Metal manufacture
- Bulk handling
- Pulp and paper industry
- General purpose industrial applications

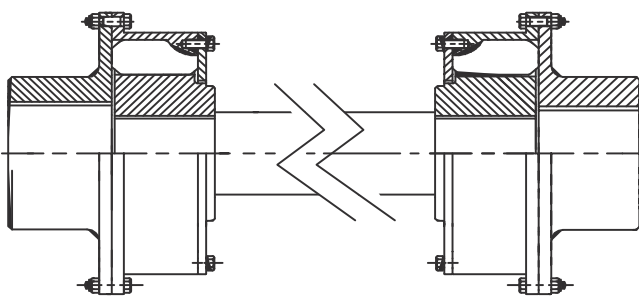

LONG SHAFT COUPLING

Long shaft coupling is used to increase the misalignment capability and halve the torsional stiffness.

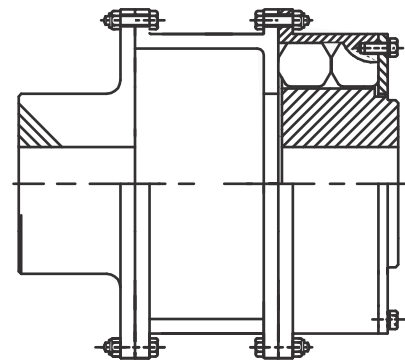

SPACER COUPLING

Used to increase the distance between shaft ends and allow easy access to driven & driving machine.

Features

- Can accommodate a wide range of shaft diameters
- Easy disconnection of the outer member and driving flange
- Coupling available with limited end float
- Shaft to shaft with increased shaft engagement

Benefits

- Allows the optimum coupling to be selected
- Allows the driving and driven machines to be disconnected
- Provides axial location for armatures with axial float

Features

- Long Boss Inner Member

Benefits

- Allows small diameter long length shafts to be used
- Reduces key stress
- Allows increased distances between shaft ends
- Full shaft engagement avoids the need for spacer collars

Coupling Size	PCI 1.4	PCI 2.1	PCI 2.6	PCI 4	PCI 8	PCI 12	PCI 23	PCI 40	PCI 60
Nominal Torque T _{kn} (kNm)	0.471	0.725	0.855	1.319	2.595	4.097	7.673	13.739	19.575
Maximum Torque T _{kmax} (kNm)	1.39	2.14	2.58	3.95	8.03	12.15	22.95	41.10	61.50
Vibratory Torque T _{kw} (kNm)	0.183	0.282	0.333	0.513	1.008	1.593	2.984	5.342	7.613
Allowable Dissipated Heat at Ambient Temperature of 30° C P _{kW} (Watts)	100	138	154	173	228	250	302	410	520
Dynamic Torsional Stiffness C _{Tdyn} (MNm/rad)									
@0.10 T _{kn}	0.010	0.013	0.016	0.025	0.050	0.076	0.143	0.220	0.499
@0.25 T _{kn}	0.014	0.018	0.021	0.034	0.068	0.102	0.193	0.297	0.673
@0.5 T _{kn}	0.029	0.037	0.045	0.070	0.141	0.214	0.405	0.621	1.326
@0.75 T _{kn}	0.062	0.080	0.096	0.148	0.301	0.456	0.861	1.320	2.533
@1.0 T _{kn}	0.107	0.137	0.166	0.254	0.517	0.782	1.477	2.268	4.153
Radial Stiffness - No Load (N/mm)									
	2136	2209	2504	2800	3680	4050	5008	5600	6170
Radial Stiffness - @ T _{kn} (N/mm)									
	6768	8365	9523	10577	14300	15340	19045	24800	31400
Axial Stiffness - No Load (N/mm)									
	177	198	245	258	319	342	413	516	683
Max. Axial Force - @ T _{kn} (N)									
	3250	4000	4400	4500	6500	7250	8750	11500	14500

Rubber Grade	Temp _{max} °C	S _t	Dynamic Magnifier (M ₃₀)	Relative Damping Ψ 30
SM80	100	S _{t100} 0.58	4	1.57

COUPLING WITH LONG BOSS INNER MEMBER

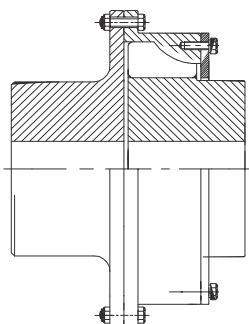

Coupling with long boss inner member and large boss driving flange to increase shaft engagement and to accept larger shafts

BRAKE DISC COUPLING

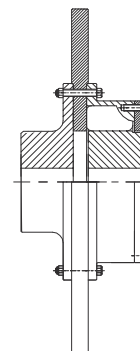

Coupling with brake disc for use on cranes, fans and conveyor drives. Brake drum couplings are also available.

ENGINEERED TO ORDER COUPLINGS (ETO)

We design and manufacture couplings to custom fit the drive and driven components for one to one replacement. Our engineering expertise create value added offering for the products by taking efforts to design, develop, analyse, engineer and test.

Engineered to Order Couplings (ETO):

- Cardan Shaft
- Spacers of various dimensions
- Floating / Long Shaft for large DBSE
- Brake Disc / Brake Drum
- Stub Shaft
- Limited End Float
- Underwater Coupling
- Shear Pin Device
- Long Boss Hubs for increased shaft engagement
- Splined Hub
- Special Adapters
- Slim Line
- Uni - Directional Couplings



PCPM 600 Spacer Coupling of 1200 mm dia used in a ball mill application for a gold mine in South Africa.



PCPM 27 Underwater Coupling with Shear Pin device on a river dredger in Greece.



Special PCRB 150 Coupling with splined hub for pump application.



PCPM 40 Cardan Shaft Coupling for fan drive where motor was coupled to VFD for power saving to replace fluid coupling. DBSE was more than 2 mtrs. This was for a steel plant.



High temperature blind assembly coupling.

GLOBAL PRESENCE



Regd Office: 'Sumali', 49/A/4 Erandwane,
Gulmohar Path, Pune, 411004, India



Works : Gat No. 106, At & Post Pirangut,
Taluka Mulshi, Dist. Pune 412108,
Maharashtra,India.



+ 91 8087090164 / 5



sales@poonacouplings.com
marketing@poonacouplings.com
www.poonacouplings.com