

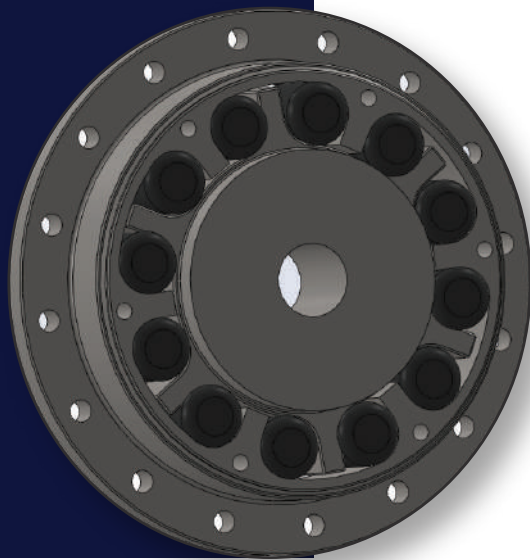

POONA
COUPLINGS
PVT. LTD.



PCRB COUPLINGS

INDUSTRIAL RANGE

The Standard Range Comprises

- Shaft to shaft
- Shaft to shaft with increased shaft engagement
- Flywheel to shaft
- Flywheel to shaft with increased shaft engagement

Construction Details

- Cast Iron to BS 17 grade
- Spheroidal graphite to BS 1563 Grade 400/15
- Separate rubber elements with a choice of grade and hardness with SM70 shore hardness being the standard
- Rubber elements are totally enclosed and loaded in compression

Features

- Intrinsically fail safe
- Control of resonant torsional vibration
- Maintenance free
- Severe shock load protection
- Misalignment capability
- Zero backlash
- Low cost

Applications

- Generator sets
 - Gear Boxes
 - Pump sets
 - Compressors
 - Wind TuPCRBinies
 - Metal manufacture
 - Bulk handling
 - Pulp and paper industry
- General purpose heavy duty industrial applications

Benefits

- Ensures continuous operation of the drive-line in the unlikely event of rubber damage
- Achieves low vibratory loads in the drive-line components by selection of optimum stiffness characteristics
- With no lubrication or adjustment required resulting in low running costs
- Avoids failure of the drive-line under short circuit and other transient conditions
- Allows axial and radial misalignment between the driving and driven machines
- Eliminates torque amplifications through precompression of rubber elements
- The coupling gives the lowest lifetime cost

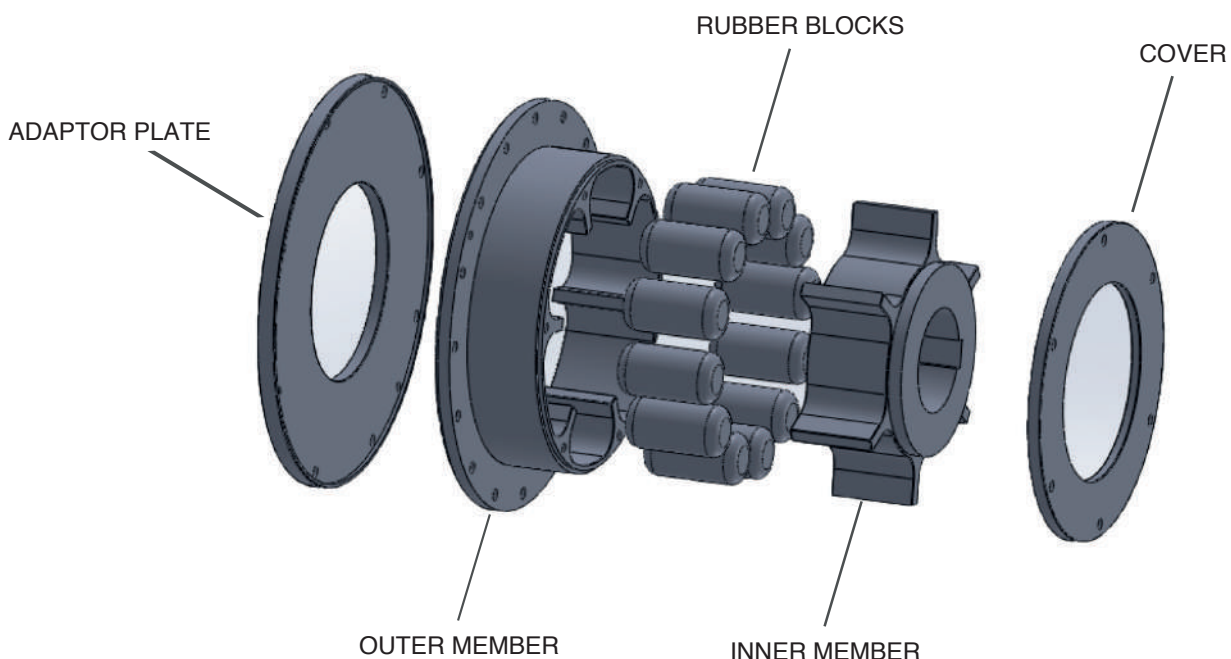

PCRB SHAFT TO SHAFT - RIGID HALF / FLEX HALF

Features

- Can accommodate a wide range of shaft diameters
- Easy disconnection of the outer member and driving flange
- Coupling available with limited end float

Benefits

- Allows the optimum coupling to be selected.
- Allows the driving and driven machines to be disconnected.
- Provides axial location for armatures with axial float

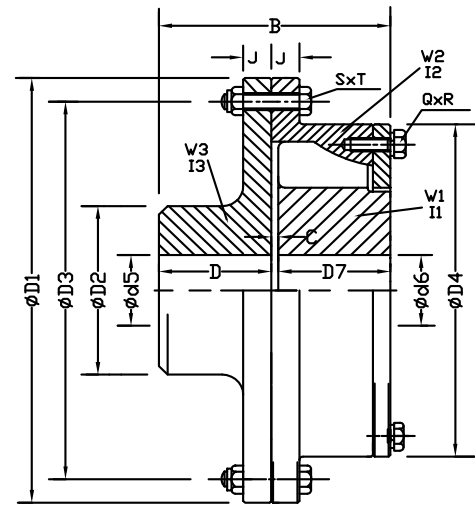

DIMENSIONS, WEIGHT, INERTIA AND ALIGNMENT

COUPLING SIZE		150	0.12	0.20	0.24	0.37	0.73	1.15	2.15	3.86	5.5
DIMENSIONS (mm)	D1	200.0	200.0	222.2	238.1	260.3	308.0	358.8	466.7	508.0	571.5
	B	85.0	104.8	111.2	123.8	136.5	174.6	193.7	233.4	260.4	285.8
	C	3.0	3.2	3.2	3.2	3.2	3.2	3.2	4.8	6.4	6.4
	D	41.0	50.8	54.0	60.3	66.7	85.7	95.2	114.3	127.0	139.7
	D7	41.0	50.8	54.0	60.3	66.7	85.7	95.2	114.3	127.0	139.7
	D2	70.0	79.4	95.2	101.6	120.6	152.4	184.1	222.2	279.4	330.2
	D3	177.80	177.80	200.00	212.70	235.00	279.40	323.80	438.15	469.90	542.92
	D4	155.0	156.5	178.0	186.5	210.0	251.0	295.0	362.0	435.0	501.5
	J	10.0	12.7	14.3	15.9	17.5	19.0	19.0	19.0	22.2	25.4
	Q	4	5	6	6	6	6	6	6	7	8
	R	M6	M8	M8	M8	M10	M10	M12	M12	M12	M12
	S	8	6	6	6	8	8	10	16	12	12
	T	M8	M8	M8	M10	M10	M12	M12	M12	M16	M16
	U (mounting hole size)	9.2	9.2	9.2	11.2	11.2	13.2	13.2	13.2	17.25	17.25
	MAX.d5	40	50	60	65	80	95	115	140	170	210
MAX.d6	40	55	70	75	85	95	115	140	170	210	
MIN. d5 & d6	20	30	35	40	40	55	55	70	80	90	
RUBBER ELEMENTS	PER CAVITY	1	1	1	1	1	1	1	1	1	1
	PER COUPLING	8	10	12	12	12	12	12	12	14	16
MAXIMUM SPEED (rPCPM) (1)		5250	5250	4725	4410	4035	3410	2925	2250	2070	1820
WEIGHT(kg) (3)	W1	1.50	2.82	4.04	5.29	7.49	12.82	23.39	35.88	62.81	102.09
	W2	2.80	4.00	5.05	6.38	8.14	13.29	18.41	33.98	43.87	59.00
	W3	3.30	4.06	5.82	7.42	10.44	18.03	27.37	47.43	75.39	113.32
INERTIA (kgm ²) (3)	I1	0.0010	0.0044	0.0084	0.0131	0.0233	0.0563	0.1399	0.3227	0.8489	1.9633
	I2	0.0140	0.0232	0.0375	0.0546	0.0887	0.2000	0.3674	1.1035	1.9161	3.4391
	I3	0.0130	0.0153	0.0270	0.0396	0.0644	0.1475	0.2862	0.7998	1.5120	2.9796
ALLOWABLE MISALIGNMENT (2)	RADIAL (mm)	0.75	0.75	0.75	0.75	0.75	1.00	1.5	1.5	1.5	1.5
	AXIAL (mm)	1.5	1.5	1.5	1.5	1.5	1.5	1.5	2.0	3.0	3.0
	CONICAL (degree)	0.5	0.5	0.5	0.5	0.5	0.5	0.5	0.5	0.5	0.5

(1) For operation above 80% of the declared maximum coupling speed, it is recommended that the coupling is dynamically balanced.

(2) Installations should be initially aligned as accurately as possible, in order to allow for deterioration in alignment over time. It is recommended that initial alignment should not exceed 25 % of the above noted data. The forces on the driving and driven machinery should be calculated to ensure that these do not exceed the manufacturers allowable.

(3) Weights and inertias are calculated based on the minimum bore size.

PCRB STANDARD SAE FLYWHEEL TO SHAFT 150 TO 1.15

Features

- Wide range of adaptor plates
- Choice of rubber compound and hardness
- Short axial length

Benefits

- Allows the coupling to be adapted to suit most engine flywheels
- Allows control of the torsional vibration system
- Allows the coupling to fit in bell house applications

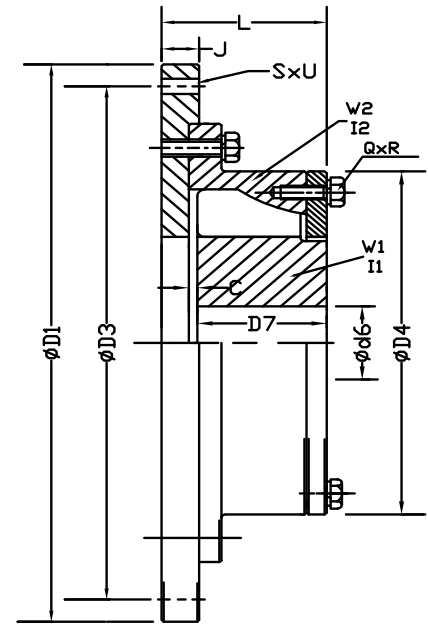

DIMENSIONS, WEIGHT, INERTIA AND ALIGNMENT

COUPLING SIZE		150		0.12		0.20		0.24		0.37		0.73		1.15	
		SAE 7.5	SAE 10	SAE 11.5	SAE 10	SAE 11.5	SAE 10	SAE 11.5	SAE 11.5	SAE 14	SAE 11.5	SAE 14	SAE 14	SAE 18	
DIMENSIONS (mm)	D1	241.3	314.3	352.4	314.3	352.4	314.3	352.4	352.4	466.7	352.4	466.7	466.7	571.5	
	C	3.0	3.2	3.2	3.2	3.2	3.2	3.2	3.2	3.2	3.2	3.2	3.2	3.2	
	D7	41.0	50.8	50.8	54.0	54.0	60.3	60.3	66.7	66.7	85.7	85.7	95.2	95.2	
	D3	222.25	295.27	333.38	295.27	333.38	295.27	333.38	333.38	438.15	333.38	438.15	438.15	542.92	
	D4	155.0	156.5	156.5	178.0	178.0	186.5	186.5	210.0	210.0	251.0	251.0	295.0	295.0	
	J	16	16	16	16	16	20	20	20	20	20	20	20	28	
	L	56.0	66.0	66.0	69.2	69.2	79.5	79.5	85.8	85.8	104.9	104.9	114.4	122.4	
	Q	4	5	5	6	6	6	6	6	6	6	6	6	6	
	R	M6	M8	M8	M8	M8	M8	M8	M10	M10	M10	M10	M12	M12	
	S	6	8	8	8	8	8	8	8	8	8	8	8	6	
	U (mounting hole size)	9.2	10.5	10.5	10.5	10.5	10.5	10.5	10.5	13.5	10.5	13.5	13.5	17.0	
	MAX.d6	40	55	55	70	70	75	75	85	85	95	95	115	115	
	MIN.d6	20	30	30	35	35	40	40	40	40	55	55	55	55	
RUBBER ELEMENTS	PER CAVITY	1	1	1	1	1	1	1	1	1	1	1	1		
	PER COUPLING	8	10	10	12	12	12	12	12	12	12	12	12		
MAXIMUM SPEED (rPCPM) (1)		4773	4773	4339	4295	3905	3710	3305	3305	2500	3310	2500	2500	2040	
WEIGHT (kg) (3)	W1	1.50	2.90	2.90	4.00	4.00	5.29	5.29	7.49	7.49	12.82	12.82	23.39	23.39	
	W2	7.80	12.4	14.8	13.8	16.2	15.71	17.10	19.96	28.76	24.01	35.31	39.03	61.00	
INERTIA (kgm ²) (3)	I1	0.001	0.004	0.004	0.008	0.008	0.0131	0.0131	0.0233	0.0233	0.0563	0.0563	0.1399	0.1399	
	I2	0.054	0.132	0.202	0.146	0.216	0.1922	0.2546	0.3087	0.7487	0.4000	0.8900	1.0274	2.3974	
ALLOWABLE MISALIGNMENT (2)	RADIAL (mm)	0.75	0.75	0.75	0.75	0.75	0.75	0.75	0.75	0.75	1	1.0	1.5	1.5	
	AXIAL (mm)	1.5	1.5	1.5	1.5	1.5	1.5	1.5	1.5	1.5	1.5	1.5	1.5	1.5	
	CONICAL (degree)	0.5	0.5	0.5	0.5	0.5	0.5	0.5	0.5	0.5	0.5	0.5	0.5	0.5	

(1) For operation above 80% of the declared maximum coupling speed, it is recommended that the coupling is dynamically balanced.

(2) Installations should be initially aligned as accurately as possible, in order to allow for deterioration in alignment over time. It is recommended that initial alignment should not exceed 25 % of the above noted data. The forces on the driving and driven machinery should be calculated to ensure that these do not exceed the manufacturers allowable.

(3) Weights and inertias are calculated based on the minimum bore size.

PCRB STANDARD SAE FLYWHEEL TO SHAFT (2.15 TO 5.5)

KEEP PLATE (2.15 SAE 14 & 5.5 SAE 18)

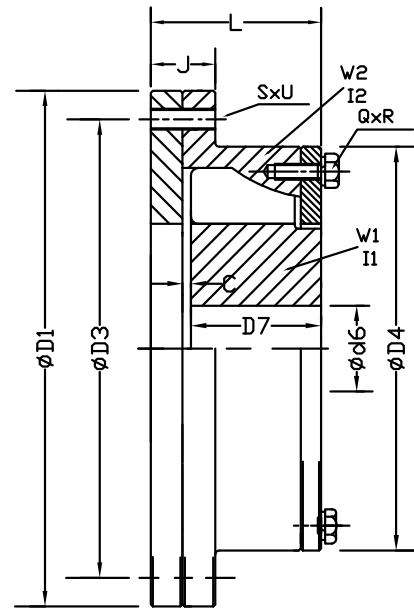
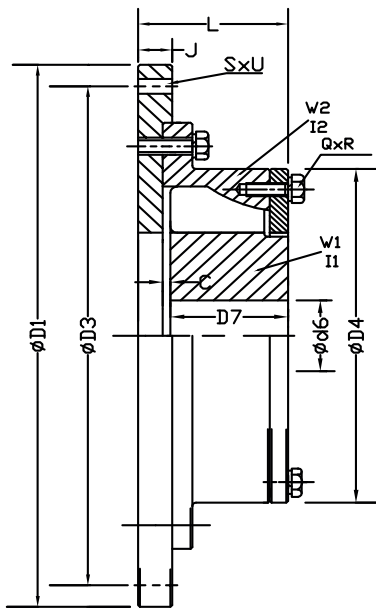

DIMENSIONS, WEIGHT, INERTIA AND ALIGNMENT

COUPLING SIZE		2.15			3.86			5.5		
		SAE 14	SAE 18	SAE 21	SAE 18	SAE 21	SAE 24	SAE 18	SAE 21	SAE 24
DIMENSIONS (mm)	D1	466.7	571.5	673.1	571.5	673.1	733.4	571.5	673.1	733.4
	C	4.8	4.8	4.8	6.4	6.4	6.4	6.4	6.4	6.4
	D7	114.3	114.3	114.3	127.0	127.0	127.0	139.7	139.7	139.7
	D3	438.15	542.92	641.35	542.92	641.35	692.15	542.92	641.35	692.15
	D4	362.0	362.0	362.0	435.0	435.0	435.0	501.5	501.5	501.5
	J	35.0	28.0	28.0	28.0	31.0	31.0	41.4	28.0	31.0
	L	135.05	143.00	143.00	157.35	160.35	160.35	162.05	170.00	173.05
	Q	6	6	6	7	7	7	8	8	8
	R	M12	M12	M12	M12	M12	M12	M12	M12	M12
	S	8	6	12	6	12	12	12	12	12
	U (mounting hole size)	13.2	17.0	17.0	17.0	17.0	22.0	17.0	17.0	22.0
	MAX.d6	140	140	140	170	170	170	210	210	210
	MIN.d6	70	70	70	80	80	80	90	90	90
RUBBER ELEMENTS	PER CAVITY	1	1	1	1	1	1	1	1	1
	PER COUPLING	12	12	12	14	14	14	16	16	16
MAXIMUM SPEED (rPCPM) (1)		2500	2040	1800	2040	1800	1590	2040	1800	1590
WEIGHT (kg) (3)	W1	35.88	35.88	35.88	62.81	62.81	62.81	102.09	102.09	102.09
	W2	50.42	79.17	92.19	86.46	110.35	120.33	79.14	117.21	135.46
INERTIA (kgm ²) (3)	I1	0.3227	0.3227	0.3227	0.8489	0.8489	0.8489	1.9633	1.9633	1.9633
	I2	1.6535	3.2935	4.9935	3.9461	6.4661	8.1461	4.5684	7.3291	9.6691
ALLOWABLE MISALIGNMENT (3)	RADIAL (mm)	1.5	1.5	1.5	1.5	1.5	1.5	1.5	1.5	1.5
	AXIAL (mm)	2	2	2	3	3	3	3	3	3
	CONICAL (degree)	0.5	0.5	0.5	0.5	0.5	0.5	0.5	0.5	0.5

(1) For operation above 80% of the declared maximum coupling speed, it is recommended that the coupling is dynamically balanced.

(2) Installations should be initially aligned as accurately as possible, in order to allow for deterioration in alignment over time. It is recommended that initial alignment should not exceed 25 % of the above noted data. The forces on the driving and driven machinery should be calculated to ensure that these do not exceed the manufacturers allowable.

(3) Weights and inertias are calculated based on the minimum bore size.

PCRB STANDARD SAE FLYWHEEL TO SHAFT WITH INCREASED SHAFT ENGAGEMENT 0.24 TO 1.15

Features

- Long Boss inner member

Benefits

- Allows small diameters long length shafts to be used
- Reduces key stress
- Allows increased distances between shaft end and flywheel
- Full shaft engagement avoids the need for spacer collars

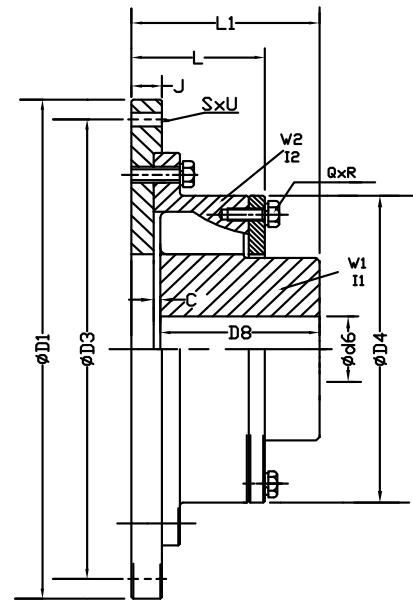

DIMENSIONS, WEIGHT, INERTIA AND ALIGNMENT

COUPLING SIZE		0.24		0.37		0.73		1.15	
		SAE 10	SAE 11.5	SAE 11.5	SAE 14	SAE 11.5	SAE 14	SAE 14	SAE 18
DIMENSIONS (mm)	D1	314.3	352.4	352.4	466.7	352.4	466.7	466.7	571.5
	C	3.2	3.2	3.2	3.2	3.2	3.2	3.2	3.2
	D8	110	110	120	120	145	145	170	170
	D3	295.27	333.38	333.38	438.15	333.38	438.15	438.15	542.92
	D4	186.5	186.5	210.0	210.0	251.0	251.0	295.0	295.0
	J	20	20	20	20	20	20	20	28
	L	79.5	79.5	85.8	85.8	104.9	104.9	114.4	122.4
	L1	129.2	129.2	139.1	139.1	164.2	164.2	189.2	197.2
	Q	6	6	6	6	6	6	6	6
	R	M8	M8	M10	M10	M10	M10	M12	M12
	S	8	8	8	8	8	8	8	6
	U (mounting hole size)	10.5	10.5	10.5	13.5	10.5	13.5	13.5	17.0
	MAX.d6	75	75	85	85	95	95	115	115
	MIN.d6	40	40	40	40	55	55	55	55
RUBBER ELEMENTS	PER CAVITY	1	1	1	1	1	1	1	1
	PER COUPLING	12	12	12	12	12	12	12	12
MAXIMUM SPEED (rPCPM) (1)		3710	3305	3305	2500	3305	2500	2500	2040
WEIGHT (kg) (3)	W1	8.67	8.67	11.85	11.85	19.43	19.43	35.28	35.28
	W2	15.71	17.10	19.96	28.76	24.01	35.31	39.03	61.00
INERTIA (kgm ²) (3)	I1	0.0193	0.0193	0.0326	0.0326	0.0770	0.0770	0.1896	0.1896
	I2	0.1922	0.2546	0.3087	0.7487	0.4000	0.8900	1.0274	2.3974
ALLOWABLE MISALIGNMENT (2)	RADIAL (mm)	0.75	0.75	0.75	0.75	1	1	1.5	1.5
	AXIAL (mm)	1.5	1.5	1.5	1.5	1.5	1.5	1.5	1.5
	CONICAL (degree)	0.5	0.5	0.5	0.5	0.5	0.5	0.5	0.5

(1) For operation above 80% of the declared maximum coupling speed, it is recommended that the coupling is dynamically balanced.

(2) Installations should be initially aligned as accurately as possible, in order to allow for deterioration in alignment over time. It is recommended that initial alignment should not exceed 25 % of the above noted data. The forces on the driving and driven machinery should be calculated to ensure that these do not exceed the manufacturers allowable.

(3) Weights and inertias are calculated based on the minimum bore size.

PCRB STANDARD SAE FLYWHEEL TO SHAFT WITH INCREASED SHAFT ENGAGEMENT 2.15 TO 5.5

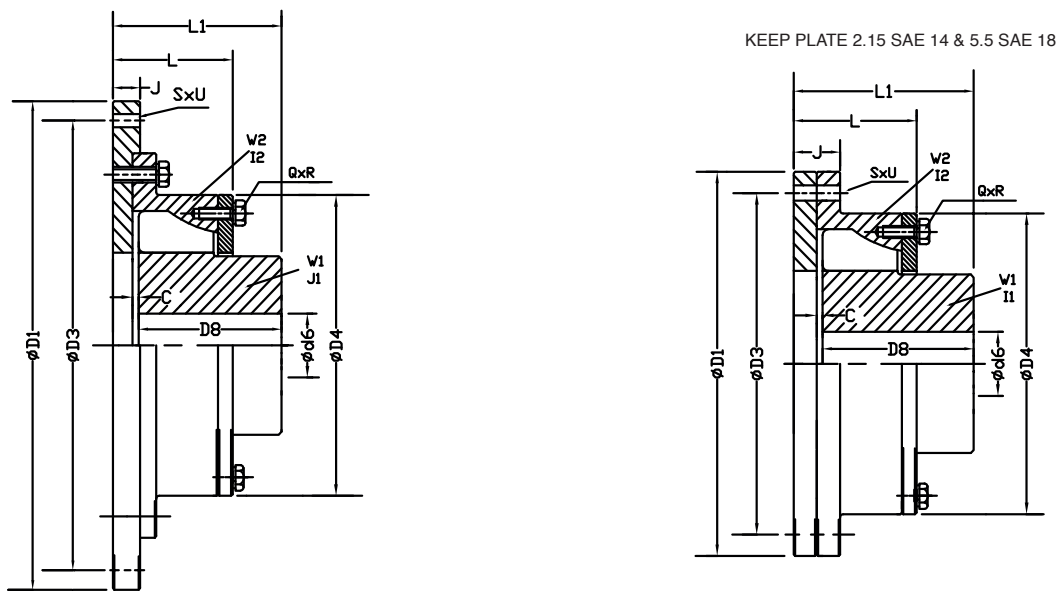

DIMENSIONS, WEIGHT, INERTIA AND ALIGNMENT

COUPLING SIZE		2.15			3.86			5.5		
		SAE 14	SAE 18	SAE 21	SAE 18	SAE 21	SAE 24	SAE 18	SAE 21	SAE 24
DIMENSIONS (mm)	D1	466.7	571.5	673.1	571.5	673.1	733.4	571.5	673.1	733.4
	C	4.8	4.8	4.8	6.4	6.4	6.4	6.4	6.4	6.4
	D8	190	190	190	210	210	210	240	240	240
	D3	438.15	542.92	641.35	542.92	641.35	692.15	542.92	641.35	692.15
	D4	362.0	362.0	362.0	435.0	435.0	435.0	501.5	501.5	501.5
	J	35.0	28.0	28.0	28.0	31.0	31.0	41.4	28.0	31.0
	L	135.00	143.00	143.00	157.35	160.35	160.35	162.05	170.00	173.00
	L1	210.7	219.7	219.7	240.4	243.4	243.4	262.4	271.3	273.3
	Q	6	6	6	7	7	7	8	8	8
	R	M12	M12	M12	M12	M12	M12	M12	M12	M12
	S	8	6	12	6	12	12	12	12	12
	U (mounting hole size)	13.2	17.0	17.0	17.0	17.0	22.0	17.0	17.0	22.0
	MAX.d6	140	140	140	170	170	170	210	210	210
	MIN.d6	70	70	70	80	80	80	90	90	90
RUBBER ELEMENTS	PER CAVITY	1	1	1	1	1	1	1	1	1
	PER COUPLING	12	12	12	14	14	14	16	16	16
MAXIMUM SPEED (rPCPM) (1)		2500	2040	1800	2040	1800	1590	2040	1800	1590
WEIGHT (kg) (3)	W1	53.81	53.81	53.81	95.50	95.50	95.50	162.79	162.79	162.79
	W2	50.42	79.17	92.19	86.46	110.35	120.33	79.14	117.21	135.46
INERTIA (kgm ²) (3)	I1	0.4347	0.4347	0.4347	1.1833	1.1833	1.1833	2.8953	2.8953	2.8953
	I2	1.6535	3.2935	4.9935	3.9461	6.4661	8.1461	4.5684	7.3291	9.6691
ALLOWABLE MISALIGNMENT (2)	RADIAL (mm)	1.5	1.5	1.5	1.5	1.5	1.5	1.5	1.5	1.5
	AXIAL (mm)	2	2	2	3	3	3	3	3	3
	CONICAL (degree)	0.5	0.5	0.5	0.5	0.5	0.5	0.5	0.5	0.5

(1) For operation above 80% of the declared maximum coupling speed, it is recommended that the coupling is dynamically balanced.

(2) Installations should be initially aligned as accurately as possible, in order to allow for deterioration in alignment over time. It is recommended that initial alignment should not exceed 25 % of the above noted data. The forces on the driving and driven machinery should be calculated to ensure that these do not exceed the manufacturers allowable.

(3) Weights and inertias are calculated based on the minimum bore size.

PCRB DESIGN VARIATIONS

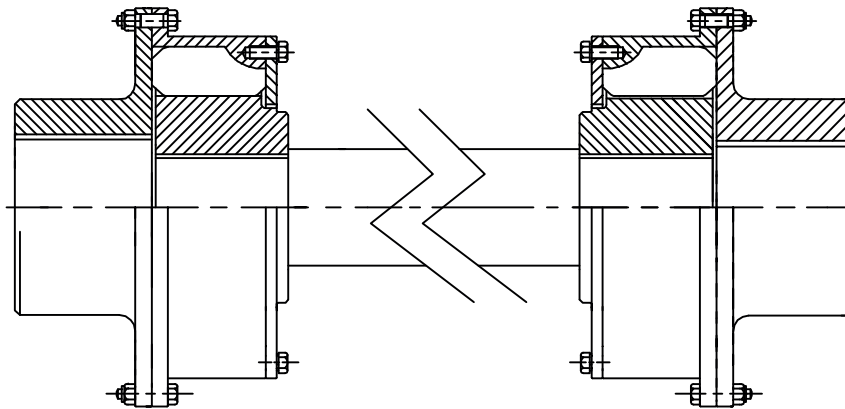

Long shaft coupling used to increase the misalignment capability and halve the torsional stiffness

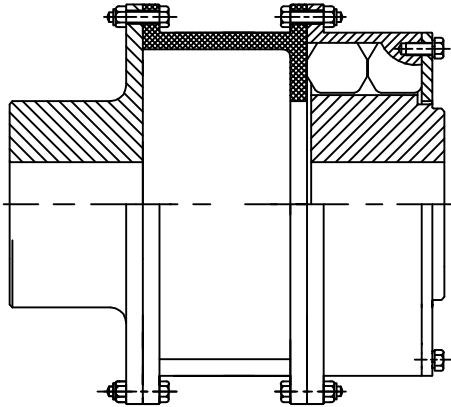

Spacer coupling used to increase the distance between shaft ends and allow easy access to driven & driving machine.

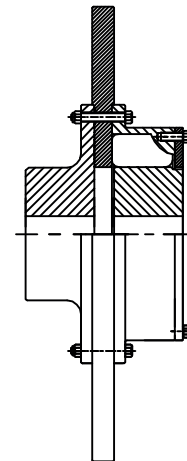

Coupling with brake disc for Cranes, Fans and Conveyor drives.

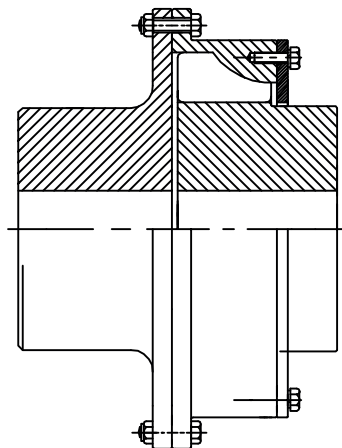

Coupling with large boss driving flange and long boss inner member for vertical applications.

PCRB TECHNICAL DATA

1.1 Diesel Engine Drives

The PCRB Coupling is selected on the "nominal torque" T_{kn} without services factors for diesel drive applications. The full torque capacity of the coupling for transient vibration whilst passing through major criticals on run up is published as the maximum torque. ($T_{kmax} = 3 \times T_{kn}$).

There is an additional torque capacity built into the coupling for short circuit and shock torques, which is $3 \times T_{kmax}$

The published "Vibratory torque T_{kw} " is a fatigue function according to DIN740 and not significant in diesel engine drives, the vibratory torque values shown in the Technical Data are at the frequency of 10Hz. The measure used for acceptability of the coupling under vibratory torque is heat dissipation of the rubber elements. The maximum allowable heat dissipation shown in the technical data is at a 30°C ambient temperature.

1.2 Industrial Drives

For industrial Electrical Motor Applications refer to the "Selection Procedures" and base the selection on T_{kmax} with the appropriate services factors. (The service factors used in the "Selection Procedures" are based upon 40 years of Poona Coupling's experience of drives and their shock frequency / amplitude. The stated T_{kmax} quoted should not be exceeded by design, without reference to PCPL.) Care needs to be taken in the design of couplings with shaft brakes to ensure the coupling torques are not increased by severe deceleration.

2.0 Stiffness Properties

The PCRB Coupling remains fully flexible under all torque conditions. The PCRB series is non-bonded type operating with the rubber-in-compression principle.

2.1 Axial Stiffness

When subject to misalignment forces in the axial direction, the coupling will have an axial resistance which gradually reduces due to the effect of vibratory torques. Given sufficient axial force as shown in the catalogue, the coupling will slip to its new position immediately.

2.2 Radial Stiffness

The radial stiffness of the coupling is torque dependent, and is as shown in the Technical Data.

2.3 Torsional Stiffness

The torsional stiffness of the coupling is dependent upon applied torque (see Technical Data) and temperature

Rubber Grade	(Temp) Max ° C	S_t
SI 70	200	$S_{t200}=0.48$
SM 60	100	$S_{t100}=0.75$
SM 70	100	$S_{t100}=0.63$
SM 80	100	$S_{t100}=0.58$
SM 70 is considered "standard"		
Rubber Grade	Dynamic Magnifier at 30°C (M_{30})	Dynamic Magnifier at 100°C (M_{100})
SM 60	8	10.7
SM 70	6	9.5
SM 80	4	6.9
SI 70	7.5	$M_{200}=15.63$
SM 70 is considered "standard"		

2.4 Prediction of the actual coupling temperature and torsional stiffness

2.4.1 Use the torsional stiffness as published in the catalogue, which is based upon data measured at 30°C and the dynamic magnifier at 30°C (M_{30})

2.4.2 Compare the synthesis value of the calculated heat load in the coupling (P_k) at the speed of interest to the "Allowable Heat Dissipation" (P_{kw}). The coupling temperature rise

The Coupling

$$\text{temperature} = ^\circ\text{C} = \text{Temp}_{\text{coup}} = \left[\frac{P_k}{P_{kw}} \right] \times 70$$

2.4.3 Calculate the temperature correction factor S_t from 2.5 (if the coupling temperature $>100^\circ\text{C}$, then use S_{t100}). Calculate the dynamic magnifier as per 2.6. Repeat the calculation with the new value of coupling stiffness and dynamic magnifier.

2.4.4 Calculate the coupling temperature as per 2.4. Repeat calculation until the coupling temperature agrees with the correction factors for torsional stiffness and dynamic magnifier used in the calculation.

PCRB TECHNICAL DATA

2.5 Temperature Correction Factor

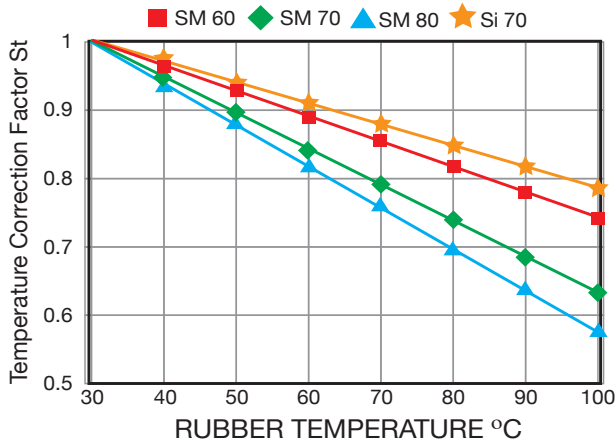

2.6 Dynamic magnifier Correction Factor

The Dynamic Magnifier of the rubber is subject to temperature variation in the same way as the torsional stiffness.

$$M_T = \frac{M_{30}}{S_t} \quad \phi_T = \phi_{30} \times S_t$$

Rubber Grade	Dynamic Magnifier (M ₃₀)	Relative Damping ψ ₃₀
SM 60	8	0.78
SM 70	6	1.05
SM 80	4	1.57
Si70	7.5	0.83

SM 70 is considered "standard"

COUPLING SIZE		150	0.12	0.20	0.24	0.37	0.73	1.15	2.15	3.86	5.5	
NOMINAL TORQUE T _{kn} (kNm)		0.150	0.314	0.483	0.570	0.879	1.730	2.731	5.115	9.159	13.050	
MAXIMUM TORQUE T _{kmax} (kNm)		0.450	0.925	1.425	1.720	2.635	5.350	8.100	15.303	27.400	41.000	
VIBRATORY TORQUE T _{kw} (kNm)		0.061	0.122	0.188	0.222	0.342	0.672	1.062	1.989	3.561	5.075	
ALLOWABLE DISSIPATED HEAT AT AMBIENT TEMP 30°C P _{kw} (W)		SM60: 45 SM70: 49 SM80: 50	90 98 100	112 123 138	125 138 154	140 155 173	185 204 228	204 224 250	246 270 302	336 369 410	426 465 520	
DYNAMIC TORSIONAL STIFFNESS C _{Tydn} (MNm/rad)												
@	0.25 T _{kn}	SM60	0.0055	0.007	0.009	0.010	0.016	0.032	0.049	0.093	0.142	0.186
		SM70	0.0070	0.011	0.014	0.017	0.026	0.052	0.079	0.150	0.230	0.300
		SM80	0.0103	0.016	0.021	0.025	0.039	0.079	0.119	0.225	0.346	0.453
@	0.5 T _{kn}	SM60	0.011	0.016	0.021	0.025	0.038	0.078	0.118	0.223	0.343	0.449
		SM70	0.014	0.022	0.028	0.034	0.052	0.105	0.159	0.300	0.460	0.602
		SM80	0.0205	0.026	0.033	0.040	0.062	0.125	0.189	0.358	0.549	0.719
@	0.75 T _{kn}	SM60	0.0165	0.035	0.045	0.054	0.082	0.167	0.253	0.479	0.735	0.962
		SM70	0.021	0.043	0.055	0.066	0.101	0.205	0.310	0.586	0.900	1.178
		SM80	0.0308	0.049	0.063	0.076	0.117	0.238	0.360	0.680	1.043	1.366
@	1.0 T _{kn}	SM60	0.022	0.057	0.073	0.088	0.134	0.273	0.413	0.780	1.197	1.567
		SM70	0.028	0.066	0.085	0.103	0.157	0.319	0.483	0.912	1.400	1.833
		SM80	0.041	0.078	0.100	0.121	0.185	0.377	0.570	0.077	1.653	2.164
RADIAL STIFFNESS NO LOAD (N/mm)	SM60	510	1020	1260	1435	1594	2116	2310	2870	3740	4728	
	SM70	628	1255	1550	1765	1962	2586	2845	3530	4600	5810	
	SM80	864	1728	2135	2430	2700	3654	3915	4860	6330	8008	
RADIAL STIFFNESS @T _{kn} (N/mm)	SM60	1023	2046	2536	2880	3207	4250	4650	5780	7520	9510	
	SM70	1067	2134	2638	3000	3435	4396	4835	6000	7820	9890	
	SM80	1155	2310	2855	3250	3610	4885	5235	6500	8465	10700	
AXIAL STIFFNESS NO LOAD (N/mm)	SM60	515	1030	1250	1400	1600	2095	2310	2850	3700	4700	
	SM70	550	1100	1350	1510	1710	2200	2500	3100	4100	5200	
	SM80	1470	2940	3690	4060	4620	6060	6700	8220	10760	13580	
MAX AXIAL FORCE (N) @T _{kn} (1)	SM60	540	1080	1350	1500	1700	2200	2460	3000	3900	5000	
	SM70	575	1150	1440	1600	1800	2360	2600	3200	4100	5300	
	SM80	650	1300	1600	1760	2000	2600	2900	3500	4600	5800	

NB. SM70 is supplied as standard rubber grade with options of rubber grades SM60 or SM80 if these are considered a better solution to a dynamic application problem. It should be noted that for operation above 80% of the declared maximum coupling speed the coupling should be dynamically balanced.

(1) The Coupling will "slip" axially when the maximum axial force is reached.

PCRB COUPLING SELECTION

To select a coupling for a given application the appropriate prime mover and driven Equipment service factors must be applied.

$$\text{Coupling Rating} = \frac{\text{hp} (\text{Prime Mover Service Factor} + \text{Driven Equipment Service Factor})}{\text{rpm}}$$

For example, the coupling rating of a centrifugal pump driven by a 6 cylinder diesel engine related to 1000 bhp at 900 rpm would be

$$\frac{1000 (1.7 + 1.25)}{900} = 3.28 \text{ hp/rpm}$$

A coupling rating of 3.86 hp/rpm would therefore be chosen.

Prime Mover Service Factors			Driven Equipment Service Factors			
Diesel Engine	1 Cylinder	*	Alternator	1.5	Crushers - Cane	3.0
	2 Cylinders	*	Banbury Mixer	3.0	Dynamometer	1.5
	3 Cylinders	2.5	Blowers - Centrifugal	1.5	Fans - Centrifugal	1.5
	4 Cylinders	2.0	Blowers - Lobe or Vane	2.0	Fans - Mine Ventilating	2.5
	5 Cylinders	1.8	Cement Mill	2.5	Generator	1.5
	6 Cylinders	1.7	Compressor - Axial Screw	1.5	Generator - Welding	2.2
More than	6 Cylinders	1.5	Compressor - Centrifugal	1.5	Machine Tool	2.0
Vee Engine		1.5	Compressor - Lobe	2.0	Pump - Centrifugal	1.25
Petrol Engine		1.5	Compressor - Reciprocating	3.0	Pump - Gear	2.0
Electric Motor / Turbines		0	Compressor - Rotary	2.0	Pump - Ram	3.0
Synchronous Motor		#	Conveyor - Belt, Chain, Screw,	1.5	Pump - Reciprocating	3.0
			Conveyor Bucket	2.0	Propeller - Marine	2.0
					Planer - Reversing	2.5

These applications require special consideration and transient response analysis.

* The application of these drive type is highly specialised so please contact POONA COUPLINGS for coupling selection. Operation at speeds in excess of catalogue maximum could be approved in certain applications. Such cases would require dynamic balancing and should only be applied following approval from POONA COUPLINGS.

* For ease of assembly the coupling rubber elements and cavity areas should be coated with silicone fluid. Insert the elements in pairs, with the second pair diametrically opposite the first and the third and four pair at 90° etc.

PCRB COUPLING SELECTION

Rubber

- Full laboratory control
- Supported by a wide range of specialised Equipment
- Maintains high quality standards
- Specialised compounds can be developed to meet specific requirements
- Standard compounds are listed below

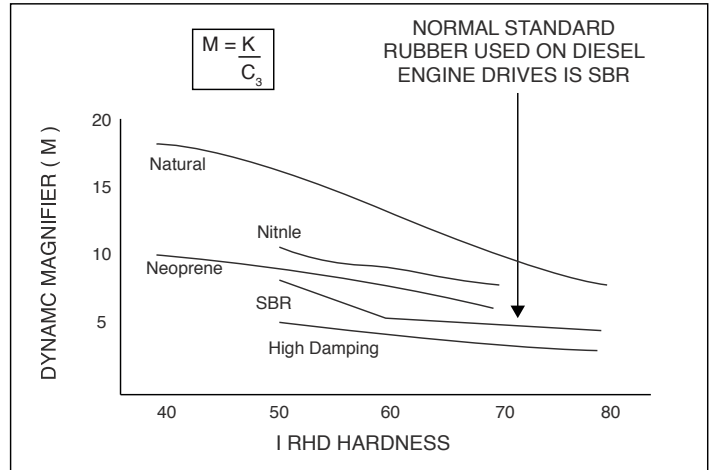

Rubber Compound

Identification Label	Natural Red (F, NM)	Styrene- Butadiene Green (SM)	Neoprene Yellow (CM)	Nitrile White (AM)	Silicone Blue (Si)
Resistance to Compression Set	Good	Good	Fair	Good	Good
Resistance to Flexing	Excellent	Good	Good	Good	Good
Resistance to Cutting	Excellent	Good	Good	Good	Fair
Resistance to Abrasion	Excellent	Good	Good	Good	Fair
Resistance to Oxidation	Fair	Fair	Very Good	Good	Excellent
Resistance to Oil & Gasoline	Poor	Poor	Good	Good	Good
Resistance to Acids	Good	Good	Fair	Fair	Good
Resistance to Water Swelling	Good	Good	Good	Good	Good
Service Temp. Maximum; Continous	80°C	100°C	100°C	100°C	200°C
Service Temp. Minimum	-50°C	-40°C	-30°C	-40°C	-50°C
			Flame Proof		

Damping Characteristics

Coupling damping varies with torsional stiffness and inversely with frequency for a given rubber grade. This relationship is conventionally described by the dynamic magnifier, M , varying with hardness for the various rubber types. This property may also be expressed as the Damping Energy Ratio or Relative Damping, Ψ , which is the ratio of the damping energy, AD , produced mechanically by the coupling during a vibration cycle and converted into heat energy, to the flexible strain energy, A_f , with respect to the mean position.

Where,

C = Specific Damping (Nms / rad)

K = Torsional Stiffness (Nm / rad)

ω = Frequency (Rad / s)

M = Dynamic Magnifier

δ = Phase Angle Rad

Ψ = Damping Energy Ratio

The rubber compound dynamic magnifier values are shown in the table below.

Rubber Grade	M
NM 45	15
SM 50	10
SM 60	8
SM 70 (is considered "standard")	6
SM 80	4

ENGINEERED TO ORDER COUPLINGS (ETO)

We design and manufacture couplings to custom fit the drive and driven components for one to one replacement. Our engineering expertise create value added offering for the products by taking efforts to design, develop, analyse, engineer and test.

Engineered to Order Couplings (ETO):

Cardan Shaft

Spacers of various dimensions

Floating / Long Shaft for large DBSE

Brake Disc / Brake Drum

Stub Shaft

Limited End Float

Underwater Coupling

Shear Pin Device

Long Boss Hubs for increased shaft engagement

Splined Hub

Special Adapters

Slim Line

Uni - Directional Couplings



PCPM 600 Spacer Coupling of 1200 mm dia used in a ball mill application for a gold mine in South Africa.



PCPM 27 Underwater Coupling with Shear Pin device on a river dredger in Greece.



Special PCRB 150 Coupling with splined hub for pump application.

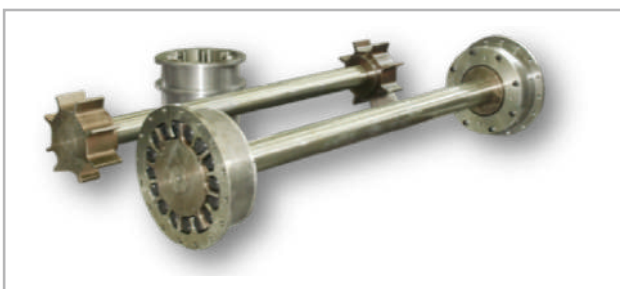

PCPM 40 Cardan Shaft Coupling for fan drive where motor was coupled to VFD for power saving to replace fluid coupling. DBSE was more than 2 mtrs. This was for a steel plant.



High temperature blind assembly coupling.

GLOBAL PRESENCE

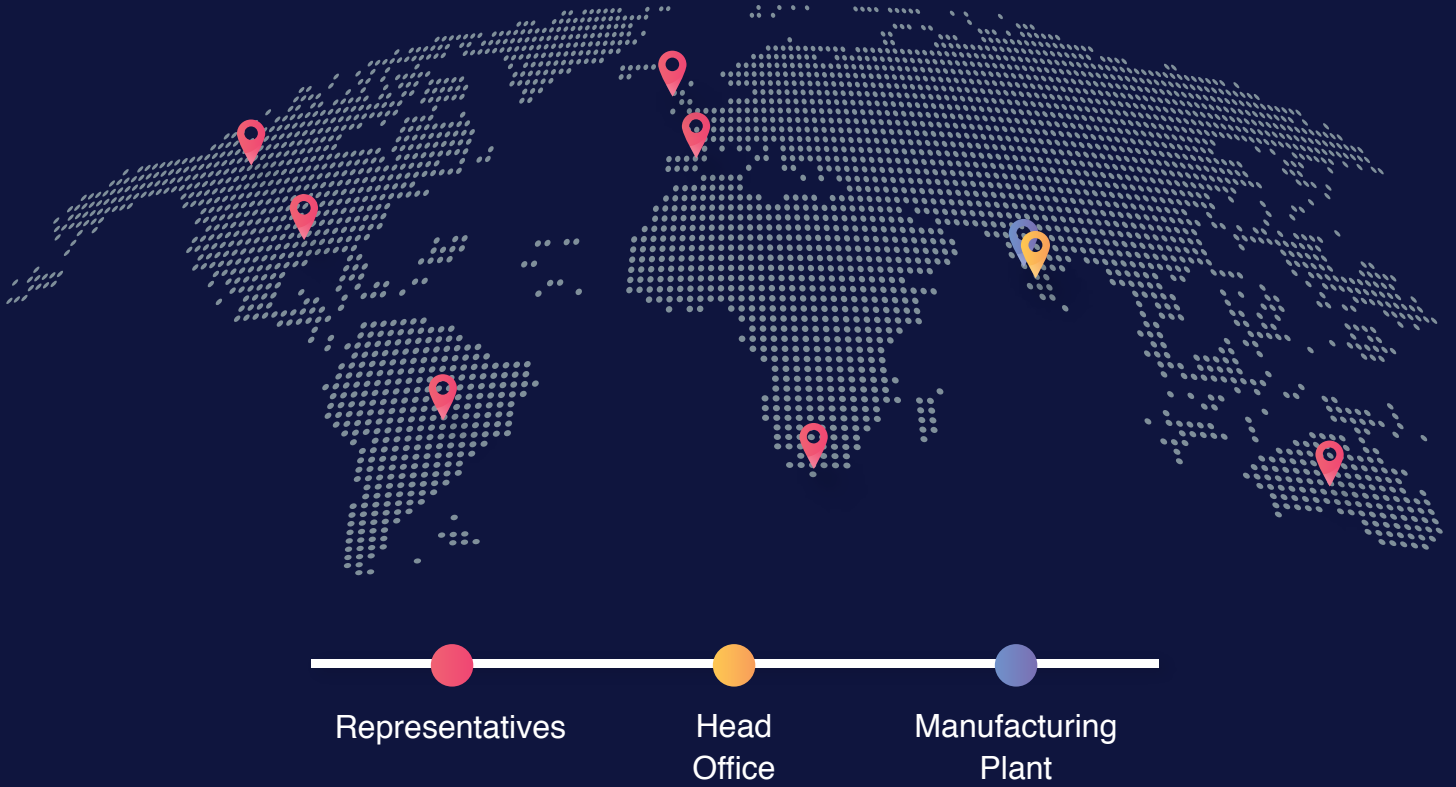

Regd Office: 'Sumali', 49/A/4 Erandwane,
Gulmohar Path, Pune, 411004, India



Works : Gat No. 106, At & Post Pirangut,
Taluka Mulshi, Dist. Pune 412108,
Maharashtra, India.



+ 91 8087090164 / 5



sales@poonacouplings.com
marketing@poonacouplings.com
www.poonacouplings.com